



# LSPS Series - IEC Safety Limit Switches EN 50047

## Operating Instructions



### Application:

IDEM Limit switches are designed to be mounted for position sensing of moving applications e.g. guard doors, conveyors, machine beds, elevators etc. They are available with linear plungers, rotary levers or roller plungers and either slow or snap action contacts. All contact blocks are positively operated to satisfy IEC 60947-5-1.

### Operation:

Operation of the switches is achieved by a sliding actuation of the moving object to cause deflection of the switch plungers or levers. For Safety applications it is important that the moving object does not pass completely over the switch actuators so as to cause the actuator to return to its original position.

### Installation guide: Correct Mounting of Limit Switches is critical to obtain optimum performance and ensure safety reliability.

Installation of all switches must be in accordance with a risk assessment for the individual application. Installation must only be carried out by competent personnel and in accordance with these instructions.

1. Never use the switch as a mechanical stop. Ensure that the actuator is protected from mechanical shock.
2. For switches with Linear actuators the actuating direction and force from the moving object should be applied in line with the axis of the plunger.
3. For switches with Rotary actuators or rollers the operating cam from the moving object should be designed such that the switch is never operated beyond its over travel position. Always use a 30 degree tapered actuating cam.
4. The heads of the switch can be rotated to obtain the best switch orientation by removing the 4 head screws and rotating the head through 90 degrees. Always ensure the 4 head screws are tightened to 1Nm to ensure switch robustness.

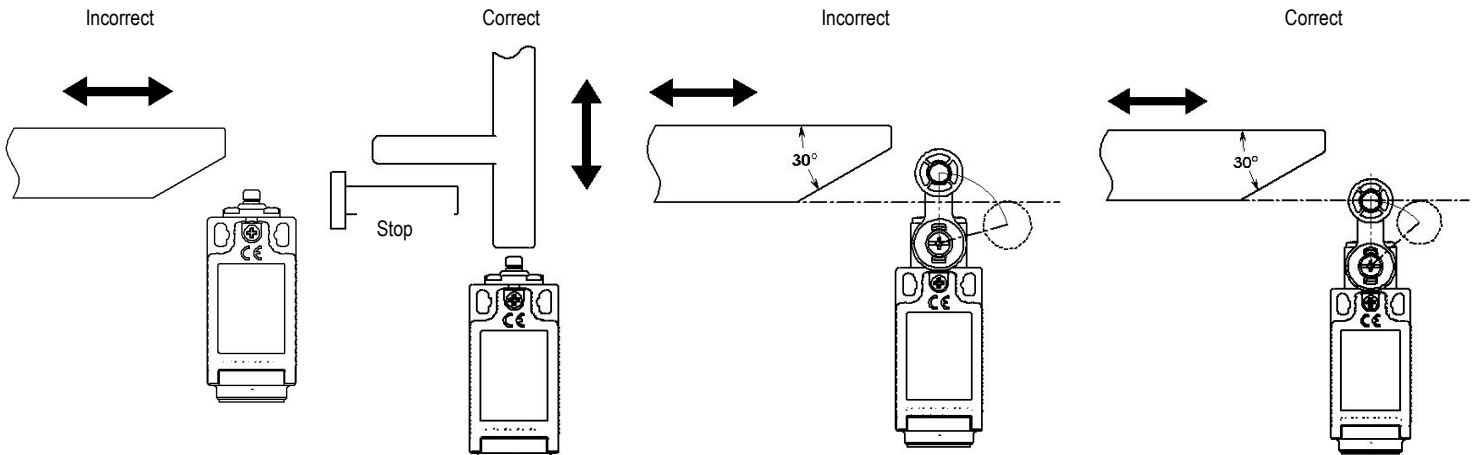

5. Always ensure that when fitting electrical conductors that they are routed correctly and do not interfere with the switch cover during fitting. Maximum conductor size is 1.5 sq.mm, contact terminal tightening torque is 1Nm.
6. Tightening torque for the lid screw is and cable glands is 1Nm to maintain IP rating.
7. Always use M4 mounting bolts and ensure 2Nm tightening torque for robust fitting.

### Maintenance:

Every Week: Check switch actuator and body for signs of mechanical damage and wear. Replace any switch showing damage.  
 Every 6 Months: Isolate power and remove cover. Check screw terminal tightness and check for signs of moisture ingress. Never attempt to repair any switch.

### Contact Blocks /Connections:

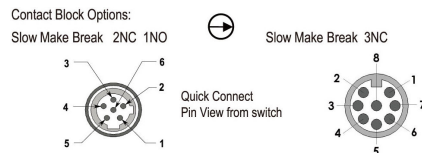

Quick Connect (QC) ½" UNF 6 Way Male	Switch Circuit	Quick Connect (QC) M12 8 Way Male (on Flying Lead 250mm) Pin view from switch
1 5	11 / 12	1 7
2 6	21 / 22 or 23 / 24	6 5
3 4	33 / 34 or 31 / 32	4 3

### Technical Specification:

Conforming to standards	EN1088 IEC 947-5-1 UL508 EN50047
Positive Opening Operation	NC Contacts
Utilization Category	AC15 A300 240V. 3A.
Min Current	5V, 5mA, DC
Thermal Current (Ith)	10A
Rated Insulation Voltage	300VAC
Rated Impulse Withstand Volt	2500VAC
Insulation Resistance	100MΩmin.(DC500V)
Contact Resistance	25mΩ max.(initial)
Max. Switching Speed	250mm/s
Max. Switching Frequency	6,000 operation per hour

Case Material	UL approved glass-filled 5VA
Roller Material	Various Polymers
Enclosure Protection	IP67
Operating Temperature	Min. -25°C Max 80°C
Pollution Degree	3
Mechanical Life Expectancy	5 x 10 <sup>6</sup> Cycle min.
Electrical Life Expectancy at full load	100,000 Cycle min.
Vibration	IEC 68-2-6, 10-55Hz 0.35mm
Conductors	1.5 sq.mm max.
Conduit Entry	M20 or ½" NPT or QD M12
Fixing	2 x M4

# LSPS Series - IEC Safety Limit Switches EN 50047

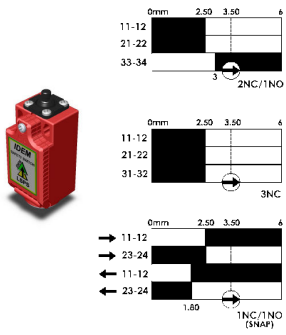

Sales Numbers		Pin Plunger	
Contacts	M20	½NPT	QD
2NC 1NO	171001	171002	171003
3NC	171004	171005	171006
1NC 1NO Snap	171007	171008	171009

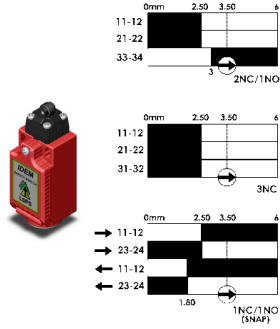

Sales Numbers		Roller Plunger	
Contacts	M20	½NPT	QD
2NC 1NO	171010	171011	171012
3NC	171013	171014	171015
1NC 1NO Snap	171016	171017	171018

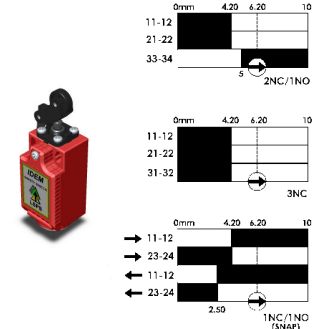

Sales Numbers		Hinge Lever	
Contacts	M20	½NPT	QD
2NC 1NO	171019	171020	171021
3NC	171022	171023	171024
1NC 1NO Snap	171025	171026	171027

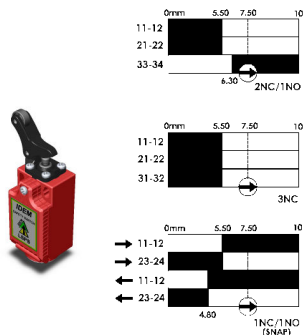

Sales Numbers		Long Hinge Lever	
Contacts	M20	½NPT	QD
2NC 1NO	171028	171029	171030
3NC	171031	171032	171033
1NC 1NO Snap	171034	171035	171036

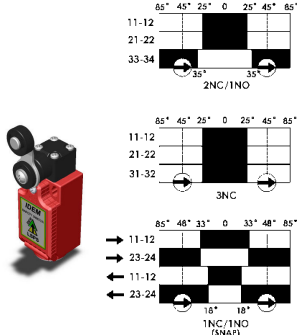

Sales Numbers		Roller Lever	
Contacts	M20	½NPT	QD
2NC 1NO	171037	171038	171039
3NC	171040	171041	171042
1NC 1NO Snap	171043	171044	171045

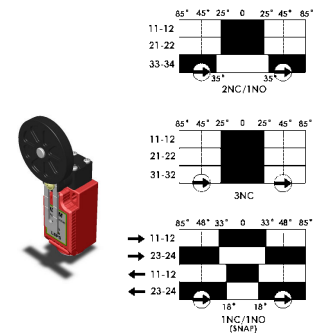

Sales Numbers		Large Roller Lever	
Contacts	M20	½NPT	QD
2NC 1NO	171046	171047	171048
3NC	171049	171050	171051
1NC 1NO Snap	171052	171053	171054

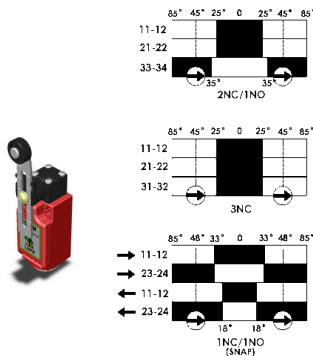

Sales Numbers		Adjustable Roller Lever	
Contacts	M20	½NPT	QD
2NC 1NO	171055	171056	171057
3NC	171058	171059	171060
1NC 1NO Snap	171061	171062	171063

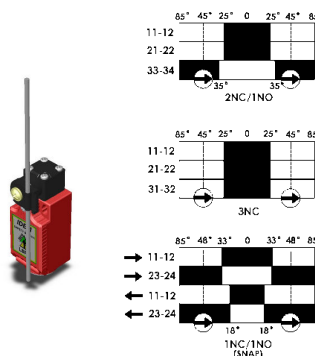

Sales Numbers		Rod Lever	
Contacts	M20	½NPT	QD
2NC 1NO	171064	171065	171066
3NC	171067	171068	171069
1NC 1NO Snap	171070	171071	171072

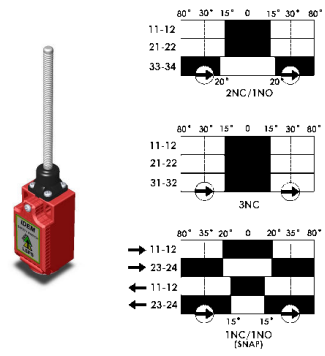

Sales Numbers		Spring Lever	
Contacts	M20	½NPT	QD
2NC 1NO	171091	171092	171093
3NC	171094	171095	171096
1NC 1NO Snap	171097	171098	171099

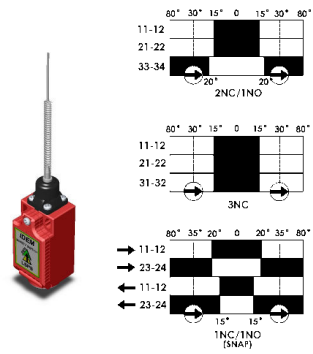

Sales Numbers		Cats Whisker	
Contacts	M20	½NPT	QD
2NC 1NO	171073	171074	171075
3NC	171076	171077	171078
1NC 1NO Snap	171079	171080	171081

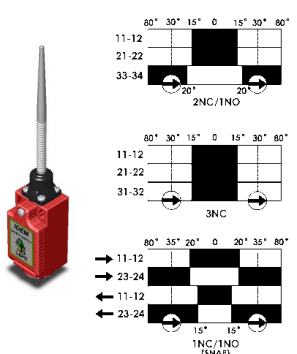

Sales Numbers		Plastic Spring Lever	
Contacts	M20	½NPT	QD
2NC 1NO	171082	171083	171084
3NC	171085	171086	171087
1NC 1NO Snap	171088	171089	171090

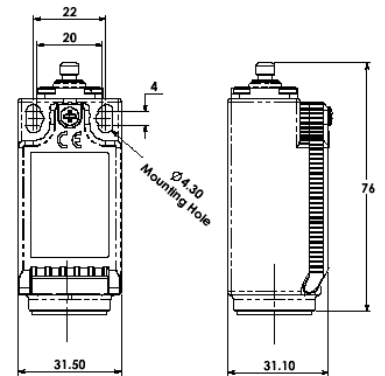

Outline dimensions - Body housing